

riscogroup.com



# VUpoint

## 4MP 25x PTZ Camera



Model: RVCM82E250



### Quick Guide

**Language**

**Page**



3



5



7



9



# IP Camera Dimensions

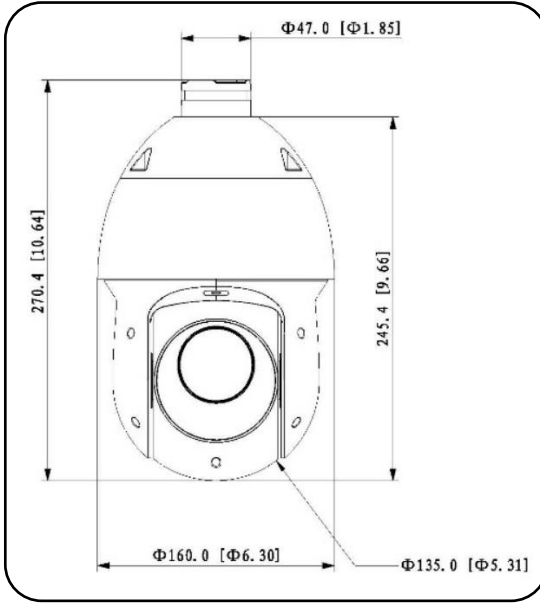

## IP Camera Settings

### Note

This camera can be connected to RISCO Cloud only via the VUpoint NVR

### Step 1

Connect one end of the network cable (LAN) to the camera Ethernet port and the other side to your router or PoE+ port. If the camera is not connected to PoE+, power it up by an appropriate power supply.

### Step 2

Use the VUpoint NVR instructions to connect the camera to the NVR using “RISCO Pro” Camera type.

## Product Specification

Parameter	Description
Image Sensor	1/2.8" STARVIS™ CMOS
IR Distance	100 m
Focal Length	4.8 – 120 mm
WDR	120 dB
Firmware Upgrade	Via the camera's web interface
Power Supply	12V/3A DC/POE+
Power Consumption	13W 21W (IR on)
Operating Conditions	-40°C to 70°C (-40°F to 158°F)/ less than ≤ 95%
Protection	IP66



## Dimensions de la caméra IP

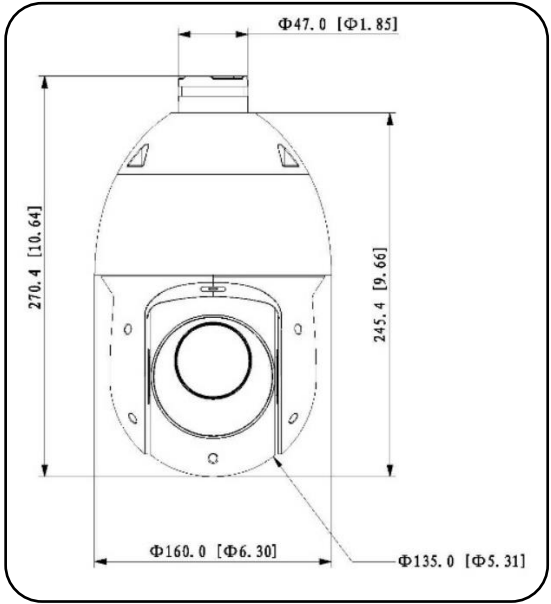

## Paramètres de la caméra IP

### Remarque

Il est possible de connecter cette caméra au cloud RISCO via le NVR VUpoint.

### Étape 1

Raccordez l'une des extrémités du câble Ethernet (LAN) au port Ethernet de la caméra, et l'autre extrémité à un routeur à un port PoE+ NVR. Si la caméra n'est pas connectée à un port PoE+, alimentez la avec une alimentation appropriée.

### Étape 2

Consultez les instructions du NVR VUpoint pour connecter la caméra au NVR avec le type de caméra « RISCO Pro ».

## Spécifications du produit

Paramètre	Description
Capteur d'image	CMOS 1/2.8" de STARVIS™
Distance IR	100 m
Focale	4.8 - 120 mm
WDR	120 dB
Mise à jour Firmware	Via l'interface web de la caméra
Alimentation	12V/3A DC/POE+
Consommation	13W 21W (IR on)
Conditions de fonctionnement	-40°C à 70°C / moins de ≤ 95%
Protection	IP66



# Dimensiones de la cámara IP

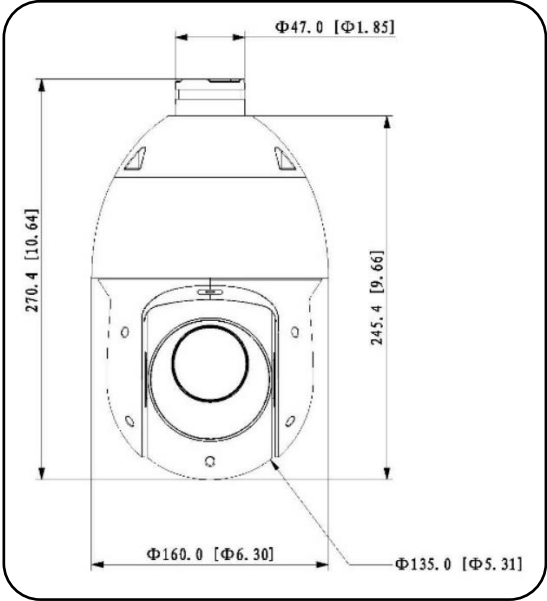

## Configuración de la cámara IP

### Nota

Esta cámara se puede conectar a RISCO Cloud solo a través del NVR de VUpoint

### Paso 1

conecte un extremo del cable Ethernet (LAN) al puerto Ethernet de la cámara y el otro extremo a un router o un puerto PoE+ NVR. Si la cámara no está conectada a alimentación POE+, conéctela a un alimentador adecuado.

### Paso 2

Consultar las instrucciones del NVR de VUpoint para conectar la cámara al NVR con el tipo de cámara "RISCO Pro".

## Especificaciones del producto

Parámetro	Descripción
Sensor de imagen	1/2.8" STARVIS™ CMOS
Distancia IR	100 m
Distancia focal	4.8 - 120 mm
WDR	120 dB
Actualización de Firmware	Desde la interfaz web de la cámara
Fuente de alimentación	12V/3A DC/POE+
Consumo de energía	13W 21W (IR on)
Condiciones de funcionamiento	-40°C a 70°C/ menos de ≤ 95%
Protección	IP66





## Dimensioni della telecamera IP

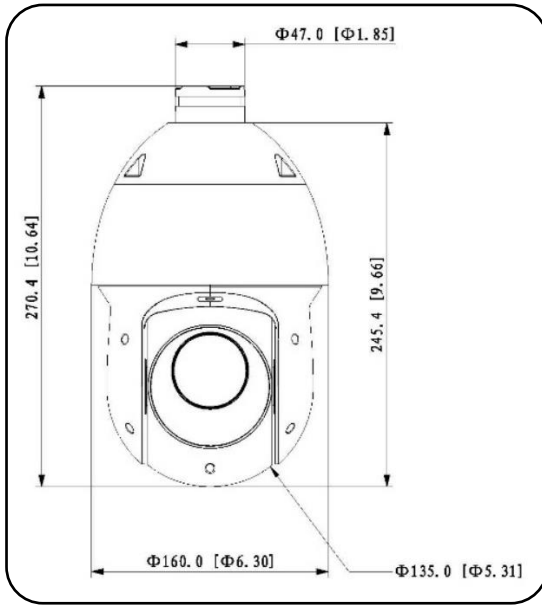

## Impostazioni telecamera IP

### Nota

Questa telecamera può essere connessa al cloud RISCO solo via NVR VUpoint

### Passo 1

Connettere un capo del cavo di rete (LAN) alla porta Ethernet della telecamera e l'altro capo alla porta PoE+ dell'NVR. Se la videocamera non è collegata al PoE +, alimentarla tramite un alimentatore appropriato.

### Passo 2

Fare riferimento alle istruzioni dell'NVR VUpoint per connettere la telecamera all'NVR usando la tipologia di telecamere "RISCO Pro".

## Specifiche Tecniche

Parametro	Descrizione
Sensore video	1/2.8" STARVIS™ CMOS
Distanza a IR	100 m
Lunghezza Focale	4.8 - 120 mm
WDR	120 dB
Aggiornamento Firmware	Tramite Web server telecamera
Alimentatore	12V/3A DC/POE+
Assorbimento	13W 21W (IR on)
Condizioni Operative	-40°C a 70°C/ meno di ≤ 95%
Protezione	IP66

## **EMC Compliance Statement:**

Hereby, RISCO Group declares that this equipment is in compliance with the essential requirements and other relevant provisions of Directive 2014/30/EU. For the CE Declaration of Conformity please refer to our website: [www.riscogroup.com](http://www.riscogroup.com).

## **Déclaration de Conformité de EMC:**

Par la présente, RISCO Group, déclare cet équipement est en conformité aux conditions essentielles et à d'autres dispositions appropriées de la directive 2014/30/EU.

Vous pouvez trouver la copie complète de la déclaration de conformité à la directive 2014/30/EU sur notre site web, à l'adresse suivante : [www.riscogroup.com](http://www.riscogroup.com).

## **Declaración de Conformidad EMC :**

Por la presente, RISCO Group declara que este equipo cumple con los requisitos esenciales y otras disposiciones relevantes de la Directiva 2014/30/EU. Para la Declaración de Conformidad CE, por favor diríjase a nuestra web: [www.riscogroup.com](http://www.riscogroup.com).

## **Dichiarazione di Conformità EMC:**

La sottoscritta RISCO Group, dichiara sotto la propria responsabilità che questo prodotto è conforme ai requisiti essenziali e alle altre rilevanti disposizioni della Direttiva Europea 2014/30/EU.

Per le Dichiarazioni di Conformità CE, visitate il nostro sito web: [www.riscogroup.com](http://www.riscogroup.com)

This device complies with part 15 of the FCC Rules. Operation is subject to the following two conditions:

- (1) This device may not cause harmful interference, and
- (2) This device must accept any interference received, including interference that may cause undesired operation.

Changes or modifications to this equipment which are not expressly approved by the party responsible for compliance (RISCO Group's.) could void the user's authority to operate the equipment.

### **FCC Note**

This equipment has been tested and found to comply with the limits for a Class B digital device, pursuant to part 15 of the FCC Rules. These limits are designed to provide reasonable protection against harmful interference in a residential installation. This equipment generates uses and can radiate radio frequency energy and, if not installed and used in accordance with the instructions, may cause harmful interference to radio communications. However, there is no guarantee that interference will not occur in a particular installation. If this equipment does cause harmful interference to radio or television reception, which can be determined by turning the equipment on and off, the user is encouraged to try to correct the interference by one or more of the following measures:

- Reorient or relocate the receiving antenna.
- Increase the separation between the equipment and the receiver.
- Connect the equipment into an outlet on a different circuit from that to which the receiver is connected.
- Consult the dealer or an experienced radio/TV technician for help.

## **Standard Limited Product Warranty (“Limited Warranty”)**

RISCO Ltd. (“**RISCO**”) guarantee RISCO’s hardware products (“**Products**”) to be free from defects in materials and workmanship when used and stored under normal conditions and in accordance with the instructions for use supplied by RISCO, for a period of (i) 24 months from the date of delivery of the Product ( the “**Warranty Period**”). This Limited Warranty covers the Product only within the country where the Product was originally purchased and only covers Products purchased as new.

**Contact with customers only.** This Limited Warranty is solely for the benefit of customers who purchased the Products directly from RISCO or from an authorized distributor of RISCO. RISCO does not warrant the Product to consumers and nothing in this Warranty obligates RISCO to accept Product returns directly from end users who purchased the Products for their own use from RISCO’s customer or from any installer of RISCO, or otherwise provide warranty or other services to any such end user directly. RISCO’s authorized distributor or installer shall handle all interactions with its end users in connection with this Limited Warranty. RISCO’s authorized distributor or installer shall make no warranties, representations, guarantees or statements to its end users or other third parties that suggest that RISCO has any warranty or service obligation to, or any contractual privity with, any recipient of a Product.

**Remedies.** In the event that a material defect in a Product is discovered and reported to RISCO during the Warranty Period, RISCO shall accept return of the defective Product in accordance with the below RMA procedure and, at its option, either (i) repair or have repaired the defective Product, or (ii) provide a replacement product to the customer.

**Return Material Authorization.** In the event that you need to return your Product for repair or replacement, RISCO will provide you with a Return Merchandise Authorization Number (RMA#) as well as return instructions. Do not return your Product without prior approval from RISCO. Any Product returned without a valid, unique RMA# will be refused and returned to the sender at the sender’s expense. The returned Product must be accompanied with a detailed description of the defect discovered (“**Defect Description**”) and must otherwise follow RISCO’s then-current RMA procedure published in RISCO’s website at [www.riscogroup.com](http://www.riscogroup.com) in connection with any such return. If RISCO determines in its reasonable discretion that any Product returned by customer conforms to the applicable warranty (“**Non-Defective Product**”), RISCO will notify the customer of such determination and will return the applicable Product to customer at customer’s expense. In addition, RISCO may propose and assess customer a charge for testing and examination of Non-Defective Product.

**Entire Liability.** The repair or replacement of Products in accordance with this Limited Warranty shall be RISCO’s entire liability and customer’s sole and exclusive remedy in case a material defect in a Product is discovered and reported as required herein. RISCO’s obligation and this Limited Warranty are contingent upon the full payment by customer for such Product and upon a proven weekly testing and examination of the Product functionality.

**Limitations.** This Limited Warranty is the only warranty made by RISCO with respect to the Products. The warranty is not transferable to any third party. To the maximum extent permitted by applicable law, this Limited Warranty shall not apply and will be void if: (i) the conditions set forth above are not met (including, but not limited to, full payment by customer for the Product and a proven weekly testing and examination of the Product functionality); (ii) if the Products or any part or component thereof: (a) have been subjected to improper operation or installation; (b) have been subject to neglect, abuse, willful damage, abnormal working conditions, failure to follow RISCO's instructions (whether oral or in writing); (c) have been misused, altered, modified or repaired without RISCO's written approval or combined with, or installed on products, or equipment of the customer or of any third party; (d) have been damaged by any factor beyond RISCO's reasonable control such as, but not limited to, power failure, electric power surges, or unsuitable third party components and the interaction of software therewith or (e) any failure or delay in the performance of the Product attributable to any means of communication provided by any third party service provider, including, but not limited to, GSM interruptions, lack of or internet outage and/or telephony failure. BATTERIES ARE EXPLICITLY EXCLUDED FROM THE WARRANTY AND RISCO SHALL NOT BE HELD RESPONSIBLE OR LIABLE IN RELATION THERETO, AND THE ONLY WARRANTY APPLICABLE THERETO, IF ANY, IS THE BATTERY MANUFACTURER'S WARRANTY. RISCO does not install or integrate the Product in the end user's security system and is therefore not responsible for and cannot guarantee the performance of the end user's security system which uses the Product or which the Product is a component of.

This Limited Warranty applies only to Products manufactured by or for RISCO. Further, this Limited Warranty does not apply to any software (including operating system) added to or provided with the Products or any third-party software, even if packaged or sold with the RISCO Product. Manufacturers, suppliers, or third parties other than RISCO may provide their own warranties, but RISCO, to the extent permitted by law and except as otherwise specifically set forth herein, provides its Products "AS IS". Software and applications distributed or made available by RISCO in conjunction with the Product (with or without the RISCO brand), including, but not limited to system software, as well as P2P services or any other service made available by RISCO in relation to the Product, are not covered under this Limited Warranty. Refer to the Terms of Service at: <https://riscocloud.com/ELAS/WebUI/UserLogin/License> for details of your rights and obligations with respect to the use of such applications, software or any service. RISCO does not represent that the Product may not be compromised or circumvented; that the Product will prevent any personal injury or property loss by burglary, robbery, fire or otherwise, or that the Product will in all cases provide adequate warning or protection. A properly installed and maintained alarm may only reduce the risk of a burglary, robbery or fire without warning, but it is not insurance or a guarantee that such will not occur or will not cause or lead to personal injury or property loss. CONSEQUENTLY, RISCO SHALL HAVE NO LIABILITY FOR ANY PERSONAL INJURY, PROPERTY DAMAGE OR OTHER LOSS BASED ON ANY CLAIM AT ALL INCLUDING A CLAIM THAT THE PRODUCT FAILED TO GIVE WARNING.

EXCEPT FOR THE WARRANTIES SET FORTH HEREIN, RISCO AND ITS LICENSORS HEREBY DISCLAIM ALL EXPRESS, IMPLIED OR STATUTORY, REPRESENTATIONS, WARRANTIES, GUARANTEES, AND CONDITIONS WITH REGARD TO THE PRODUCTS, INCLUDING BUT NOT LIMITED TO ANY REPRESENTATIONS, WARRANTIES, GUARANTEES, AND CONDITIONS OF MERCHANTABILITY, FITNESS FOR A PARTICULAR PURPOSE, TITLE AND WARRANTIES AGAINST HIDDEN OR LATENT DEFECTS, TO THE EXTENT PERMITTED BY LAW. WITHOUT LIMITING THE GENERALITY OF THE FOREGOING, RISCO AND ITS LICENSORS DO NOT REPRESENT OR WARRANT THAT: (i) THE OPERATION OR USE OF THE PRODUCT WILL BE TIMELY, SECURE, UNINTERRUPTED OR ERROR-FREE; (ii) THAT ANY FILES, CONTENT OR INFORMATION OF ANY KIND THAT MAY BE ACCESSED THROUGH THE PRODUCT SHALL REMAIN SECURED OR NON DAMAGED. CUSTOMER ACKNOWLEDGES THAT NEITHER RISCO NOR ITS LICENSORS CONTROL THE TRANSFER OF DATA OVER COMMUNICATIONS FACILITIES, INCLUDING THE INTERNET, GSM OR OTHER MEANS OF COMMUNICATIONS AND THAT RISCO'S PRODUCTS, MAY BE SUBJECT TO LIMITATIONS, DELAYS, AND OTHER PROBLEMS INHERENT IN THE USE OF SUCH MEANS OF COMMUNICATIONS. RISCO IS NOT RESPONSIBLE FOR ANY DELAYS, DELIVERY FAILURES, OR OTHER DAMAGE RESULTING FROM SUCH PROBLEMS. RISCO WARRANTS THAT ITS PRODUCTS DO NOT, TO THE BEST OF ITS KNOWLEDGE, INFRINGE UPON ANY PATENT, COPYRIGHT, TRADEMARK, TRADE SECRET OR OTHER INTELLECTUAL PROPERTY RIGHT IN ANY EVENT RISCO SHALL NOT BE LIABLE FOR ANY AMOUNTS REPRESENTING LOST REVENUES OR PROFITS, PUNITIVE DAMAGES, OR FOR ANY OTHER INDIRECT, SPECIAL, INCIDENTAL, OR CONSEQUENTIAL DAMAGES, EVEN IF THEY WERE FORESEEABLE OR RISCO HAS BEEN INFORMED OF THEIR POTENTIAL.

## Contacting RISCO

RISCO Group is committed to customer service and Product support. You can contact us through our website ([www.riscogroup.com](http://www.riscogroup.com)) or at the following telephone and fax numbers:

### **United Kingdom**

Tel: +44-(0)-161-655-5500

[support-uk@riscogroup.com](mailto:support-uk@riscogroup.com)

### **Italy**

Tel: +39-02-66590054

[support-it@riscogroup.com](mailto:support-it@riscogroup.com)

### **Spain**

Tel: +34-91-490-2133

[support-es@riscogroup.com](mailto:support-es@riscogroup.com)

### **France**

Tel: +33-164-73-28-50

[support-fr@riscogroup.com](mailto:support-fr@riscogroup.com)

All rights reserved.

No part of this document may be reproduced in any form without prior written permission from the publisher.

### **Belgium (Benelux)**

Tel: +32-2522-7622

[support-be@riscogroup.com](mailto:support-be@riscogroup.com)

### **USA**

Tel: +1-631-719-4400

[support-usa@riscogroup.com](mailto:support-usa@riscogroup.com)

### **China**

Tel: +86-755-82789285

[support-cn@riscogroup.com](mailto:support-cn@riscogroup.com)

### **Israel**

Tel: +972-3-963-7777

[support@riscogroup.com](mailto:support@riscogroup.com)



© RISCO Group, 12/2020. All rights reserved.

5IN2899 B